

## **Mouldings**



## Contents

Click on the desired sub-segment to go directly to the page

		catalogue pg. nos	pdf pg. nos
<b>Mouldings</b>			
<b>Decorative moulding</b>	-----	153	3
<b>Water channels</b>	-----	159	9

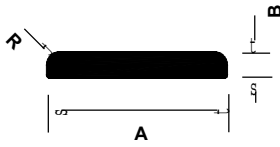

Sec	A	B	R	Kg/m
5527	16.00	3.00	3.00	0.119
5519	20.00	3.00	1.50	0.159
5506	20.00	5.00	2.50	0.263
6323	25.00	4.00	2.00	0.265
6319	25.40	1.60	0.80	0.109
5505	25.40	3.18	1.98	0.213
5531	25.40	3.18	3.18	0.206
5504	28.58	3.18	1.59	0.242
5511	31.75	3.18	1.60	0.270
5518	34.92	4.78	2.39	0.444
5513	38.10	3.18	1.98	0.323
6312	38.10	3.96	3.18	0.396
5517	38.10	9.52	4.78	0.953
5528	50.00	4.40	1.50	0.605
5523	50.00	8.00	1.50	1.077
5510	50.80	2.39	0.79	0.327
5522	88.90	3.18	1.98	0.759

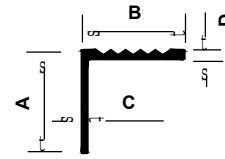

Sec	A	B	C	D	Kg/m
2035	12.00	20.00	1.20	2.00	0.121
2052	12.70	12.70	1.20	1.90	0.087
2040	16.00	16.00	1.20	2.00	0.118
2042	17.50	17.50	1.20	1.90	0.118
2001	19.84	19.05	1.60	2.77	0.181
2044	25.40	25.40	1.59	2.38	0.235
2007	23.83	23.83	1.60	2.41	0.221

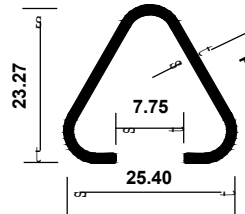

Sec	T	Kg/m
7324	1.20	0.207
7374	1.60	0.269
7354	1.50	0.255

n 7989

0.275 Kg/m

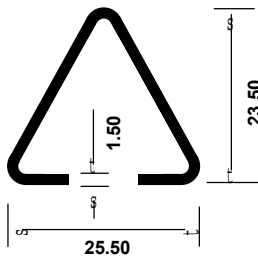

n 6726

0.152 Kg/m

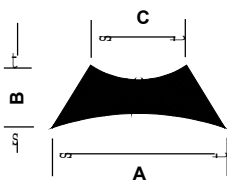
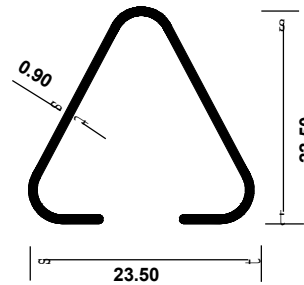

Sec	A	B	C	Kg/m
5769	25.00	4.78	14.00	0.171
5614	25.40	5.90	14.33	0.230
5606	25.40	5.92	14.29	0.230
5601	28.58	5.56	15.88	0.428

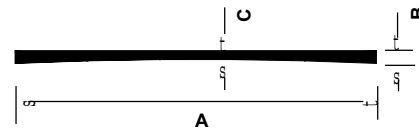

Sec	A	B	C	Kg/m
5608	57.15	2.39	1.60	0.287
6354	88.90	2.50	2.00	0.520

Sec	A	B	Kg/m
5602	19.05	2.38	0.095
5452	38.10	5.56	0.435

Sec	A	B	Kg/m
5407	15.88	3.18	0.071
5406	19.05	3.18	0.084
5408	19.05	3.96	0.118
5414	19.00	4.75	0.145
5450	22.22	3.96	0.135
5405	25.40	3.18	0.111
5415	25.40	4.75	0.152
5402	25.40	4.78	0.151
5454	26.16	4.78	0.179
5782	30.00	10.43	0.551
5451	31.75	4.78	0.268

Sec	T	Kg/m
2726	1.75	0.173
2776	0.85	0.114

n 5637 0.141 Kg/m

n 2684 0.162 Kg/m

Sec	A	B	C	D	Kg/m
1463	31.77	3.00	1.20	2.39	0.188
1450	31.77	3.96	1.60	2.39	0.246

n 5771 1.217 Kg/m

n 6401 0.396 Kg/m

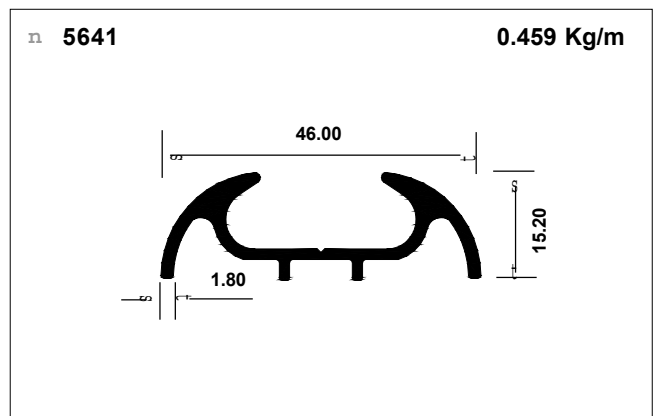
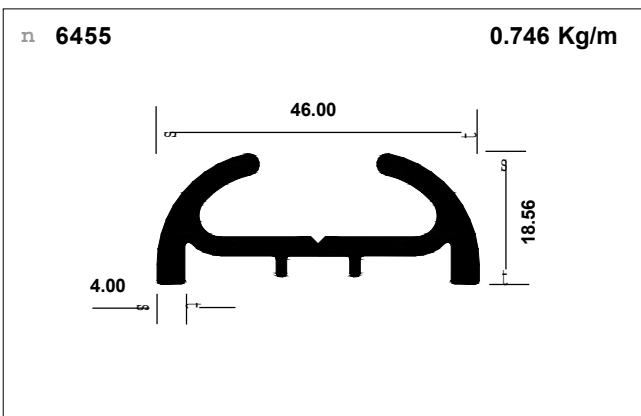
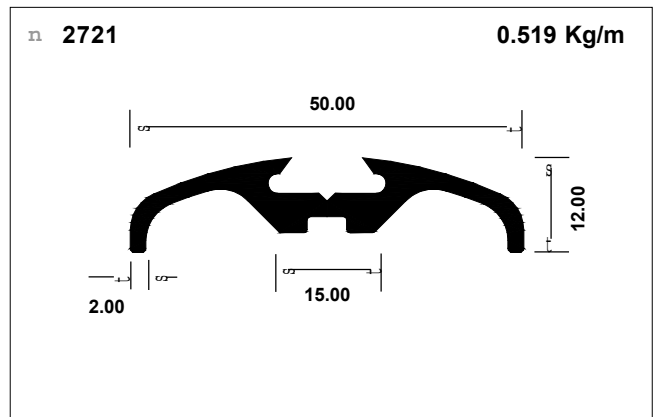
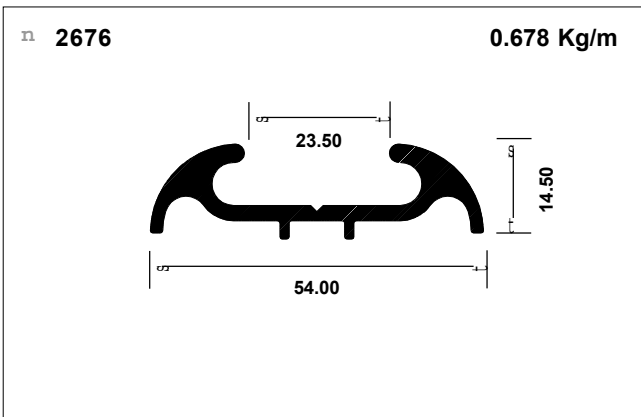
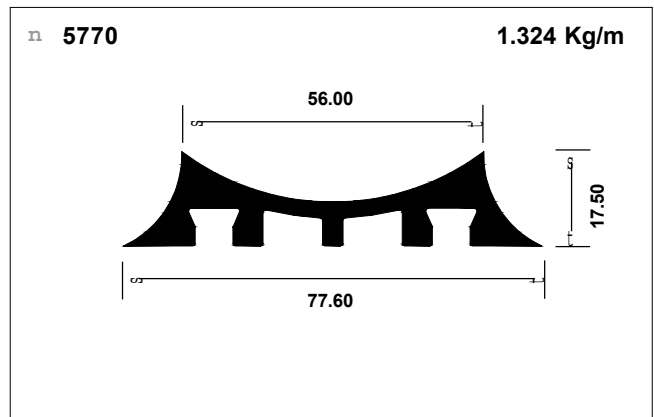
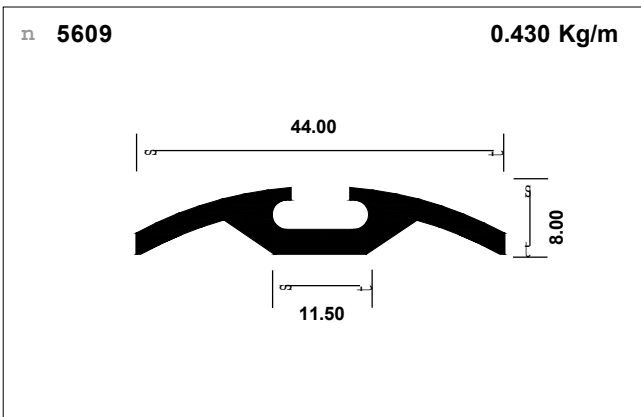
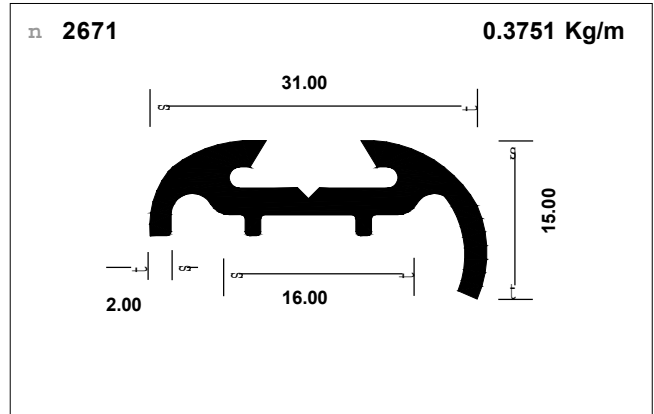
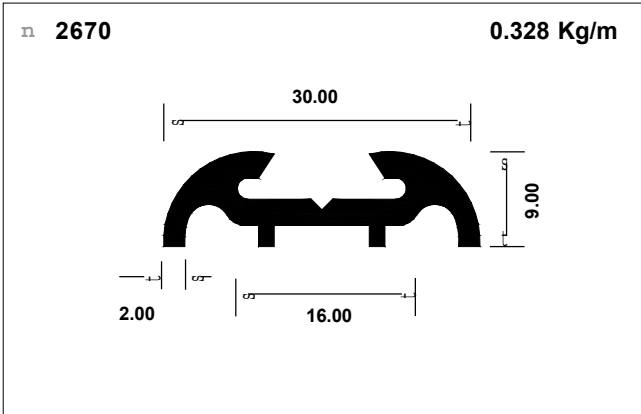

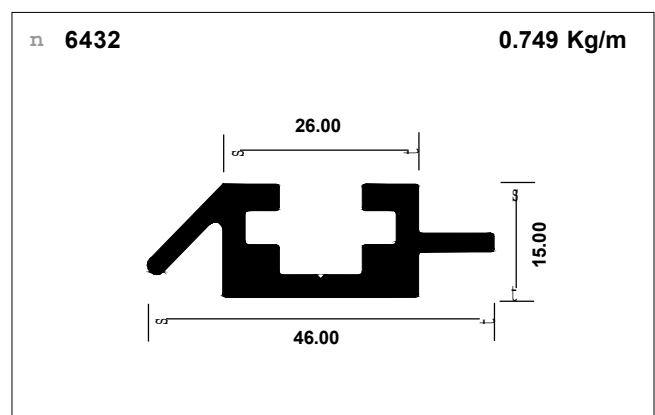
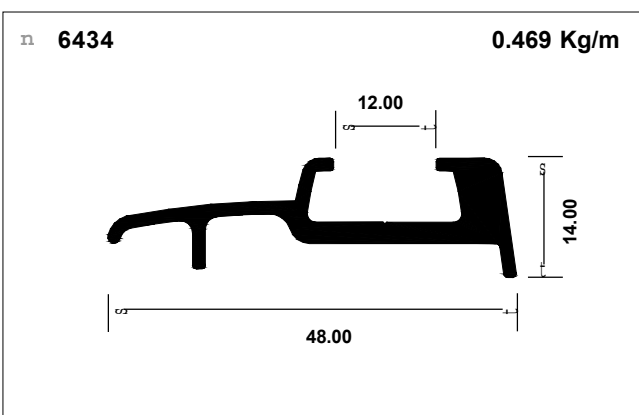
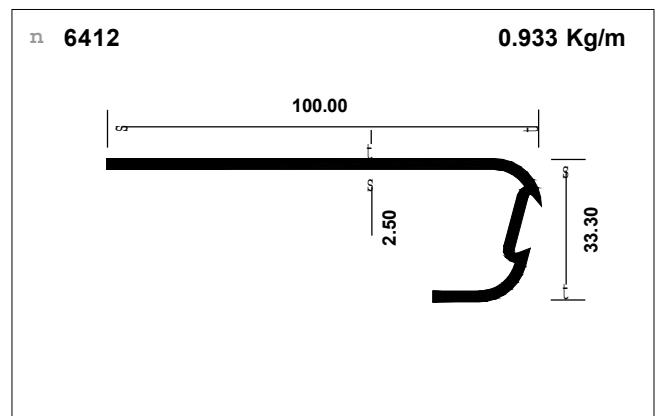
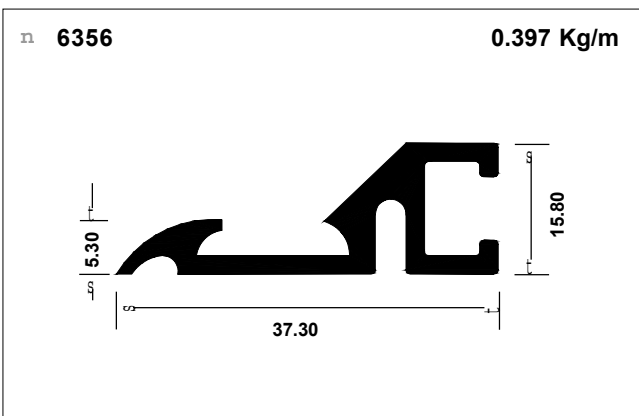
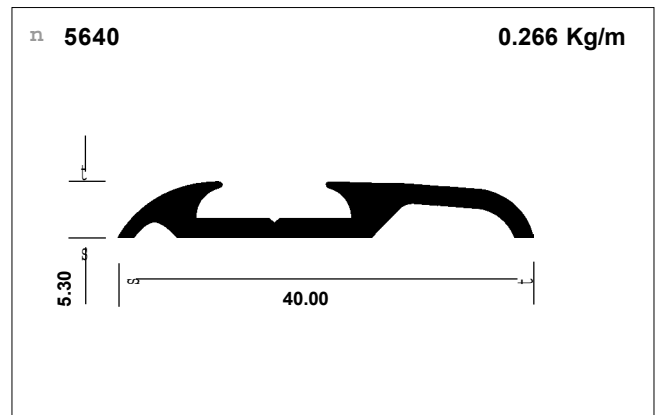
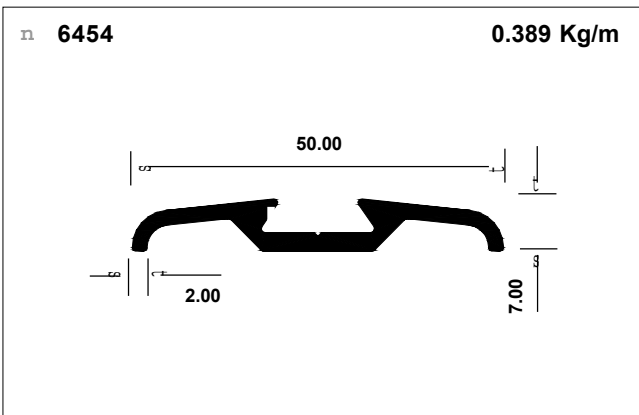
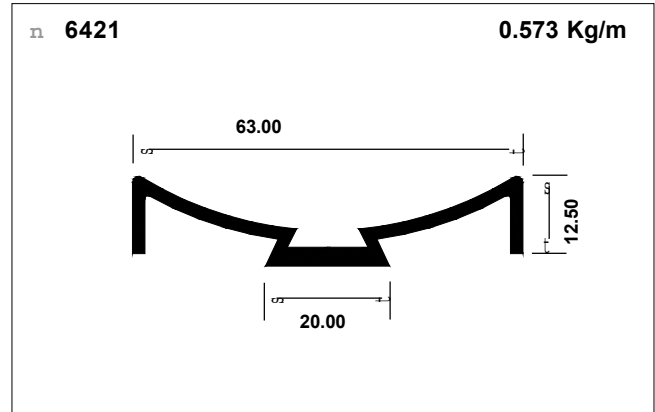
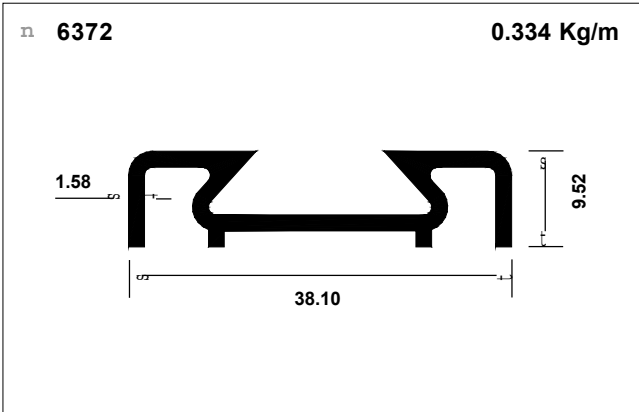

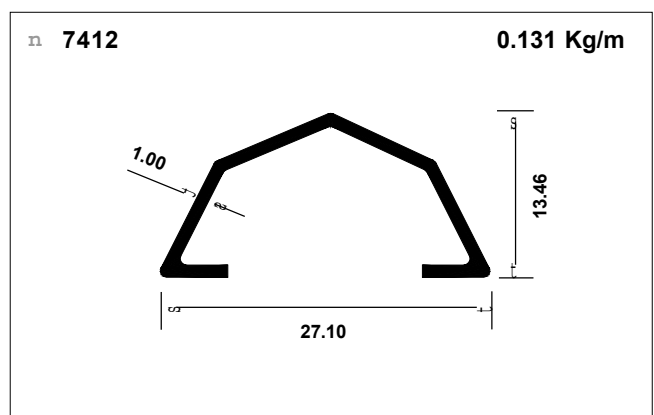
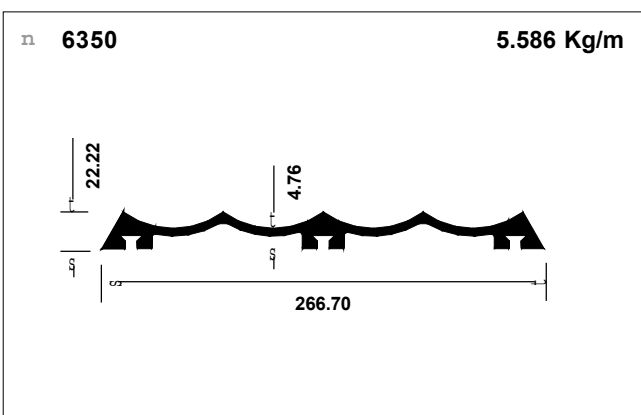
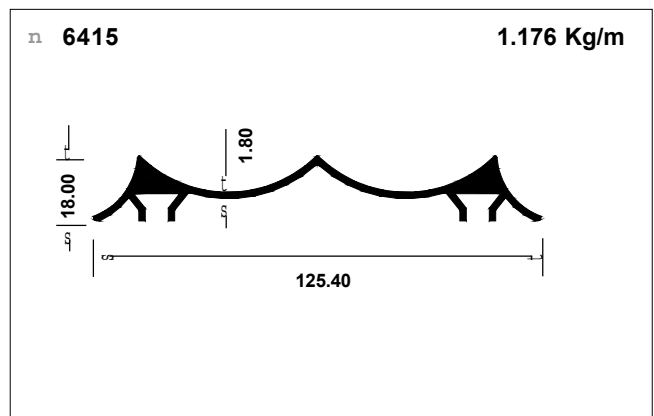
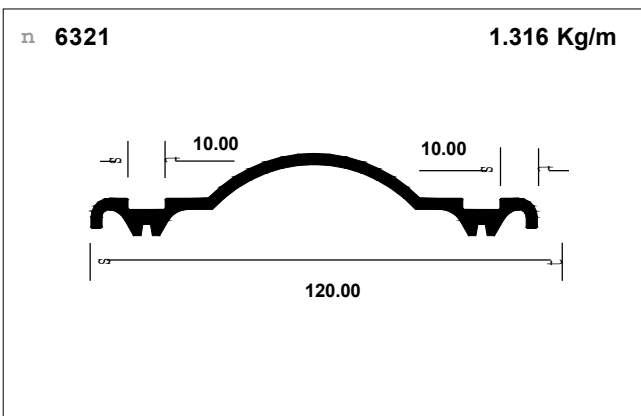
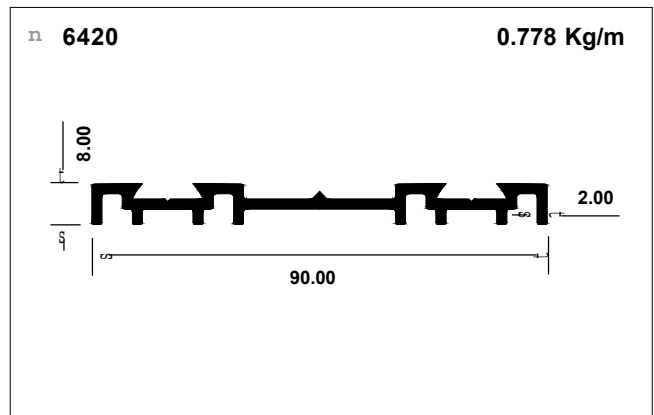
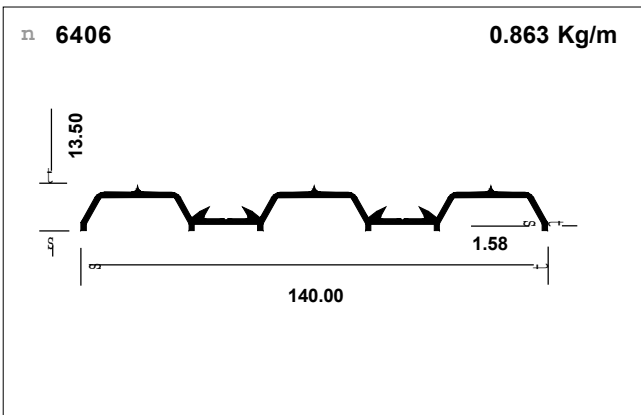
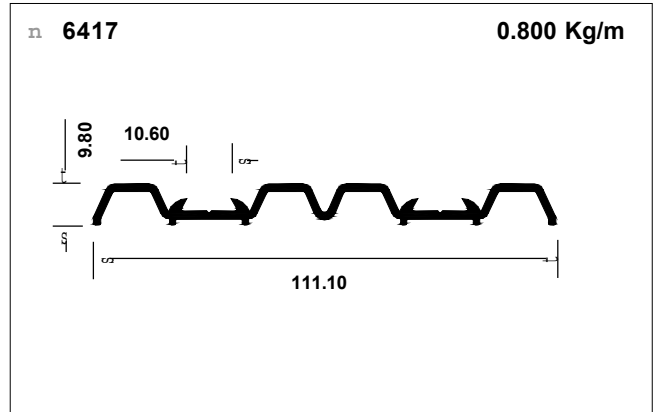
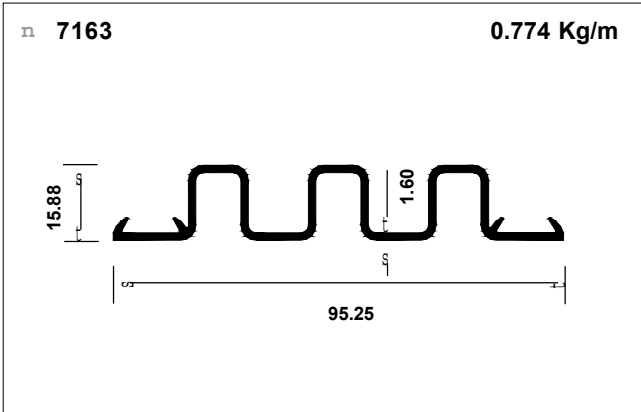

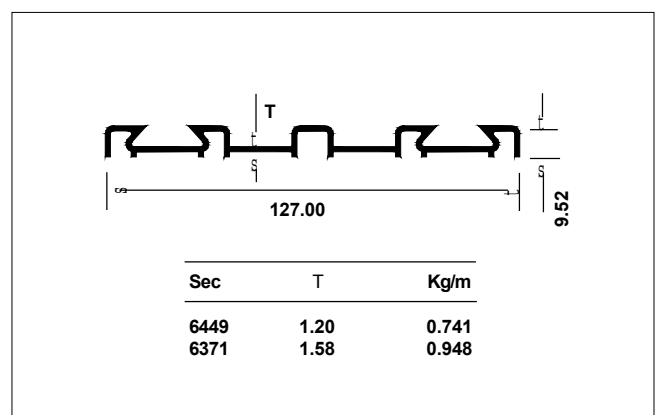
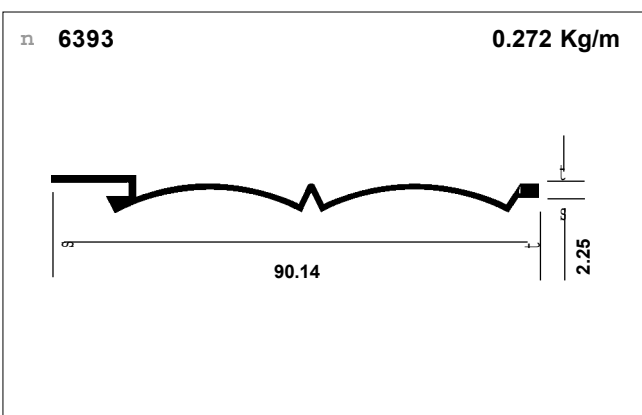
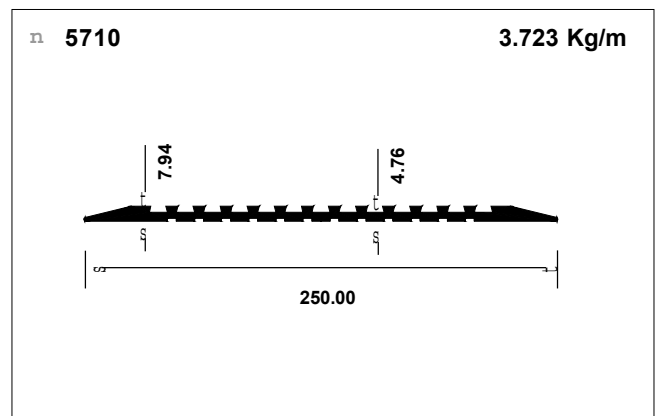
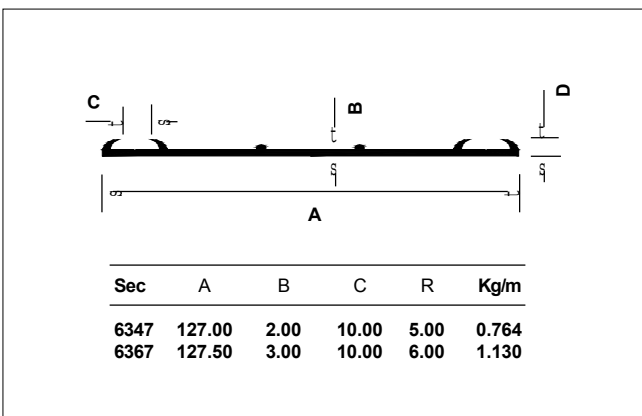
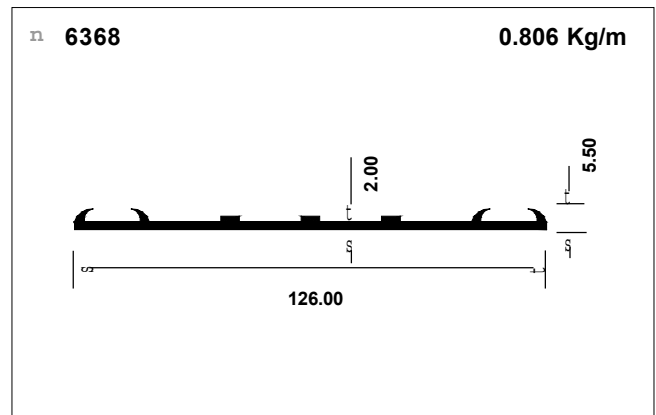
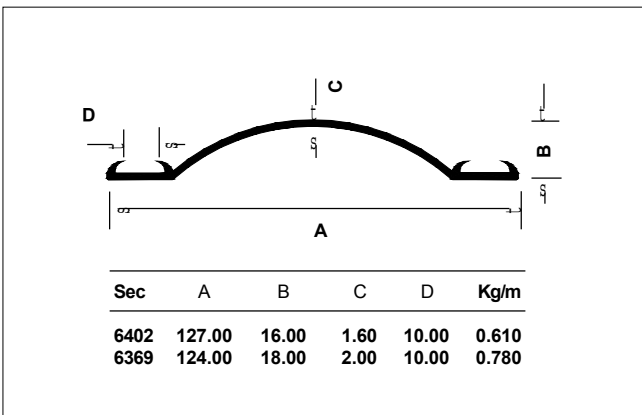
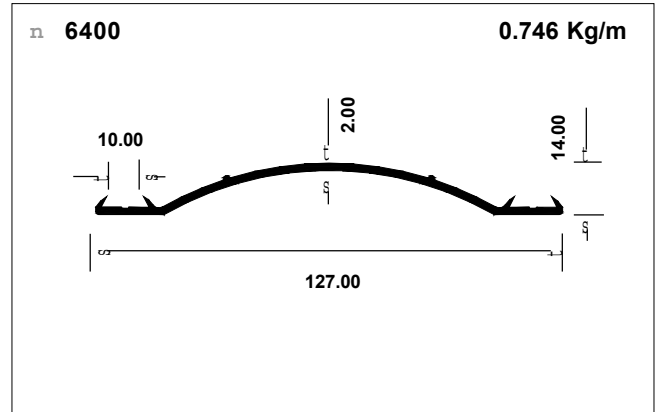
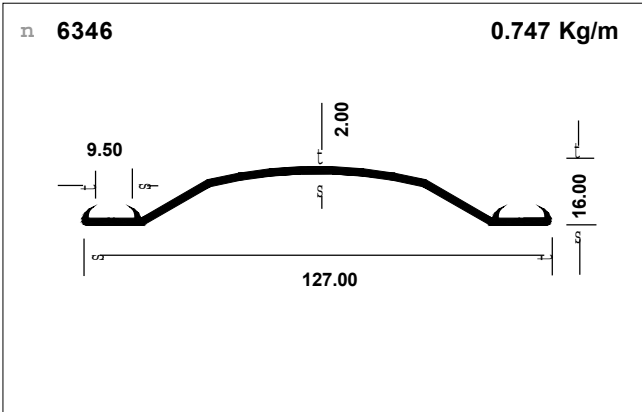



**Water Channels**

